

POPORI
ACOUSTICS

INSTALLATION AND USER MANUAL

WR1.24 SE

WIDE RANGE ELECTROSTATIC SPEAKERS

POPORI ACOUSTICS CO. LTD.



VERSION:23/3

www.poporiacoustics.com

Congratulations on purchasing one of the world's best electrostatic speakers.
With proper care, they will provide you with many years of musical enjoyment!

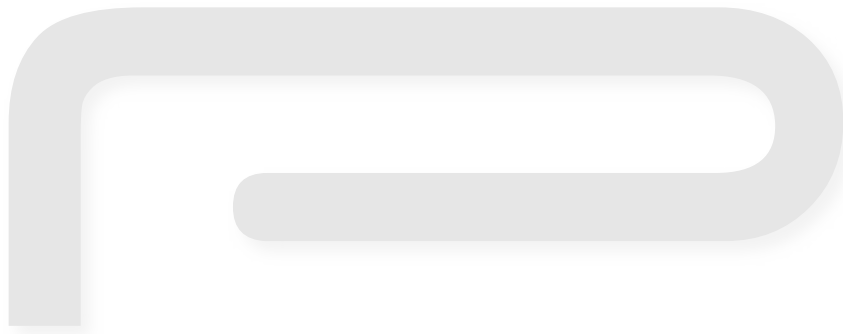

Please read this manual carefully before unpacking, moving, positioning, and the first use of your speakers. Please do not disassemble any of the electronic parts of this product or touch the electrostatic foil membrane; this will invalidate the warranty. Only the manufacturer, their authorized service agents, or distributors are authorized to open any electronic parts.

IMPORTANT SAFETY INSTRUCTIONS

Before installing the speakers, please carefully read and obey the safety and security notes and the instructions in this manual to ensure safe and reliable operation of the equipment. Not following these warnings and instructions will VOID the warranty of this product.



CAUTION: TO REDUCE THE RISK OF ELECTRIC SHOCK, DO NOT REMOVE THE COVER TO THE BLACK BOX BETWEEN THE LEGS OF THE SPEAKERS. THERE ARE NO USER-SERVICEABLE PARTS INSIDE. REFER ALL SERVICING NEEDS TO AN AUTHORIZED SERVICE AGENT.



The lightning flash with arrowhead symbol, within an equilateral triangle, is intended to alert the user to the presence of uninsulated "dangerous voltage" within the product's enclosure that may be of sufficient magnitude to constitute a risk of electric shock.



The exclamation point within an equilateral triangle is intended to alert the user to the presence of important operation and maintenance (servicing) instruction in the literature accompanying the speaker.

**WARNING:
THE APPARATUS SHALL NOT BE EXPOSED TO LIQUIDS NOR SHALL ANY OBJECT CONTAINING LIQUID BE PLACED ON THE SPEAKER.**

IMPORTANT!

- 1) Read these instructions.
- 2) Keep these instructions.
- 3) Heed all warnings.
- 4) Follow all instructions.
- 5) Do not use this apparatus near water or other liquids.
- 6) Clean only with a dry lint-free cloth or with a soft brush. **DO NOT USE A VACUUM CLEANER OR ANY TYPE OF CLEANSER OR POLISH!**
- 7) Install in accordance with the manufacturer's instructions.
- 8) Do not install this apparatus near any heat sources such as radiators, heat registers, stoves, or other apparatus (including amplifiers) that produce heat.
- 9) Do not defeat the safety purpose of the polarized or grounding-type plug. A polarized plug has two blades with one wider than the other. A grounding type plug has two blades and a third grounding prong. The wide blade or the third prong is provided for your safety. If the provided plug does not fit into your outlet, consult an electrician for replacement of the obsolete outlet.
- 10) Protect the power cord from being walked on or pinched, particularly at the plug, the receptacle, and the point where the cord exits from the apparatus.
- 11) Only use attachments/accessories specified by the manufacturer.
- 12) Unplug this apparatus during lightning storms or when unused for long periods of time.
- 13) Refer all servicing to an authorized service agent. Servicing is required when the apparatus has been damaged in any way, such as if the power-supply cord or plug is damaged, liquid has fallen into the apparatus, the apparatus has been exposed to rain or moisture, or if the apparatus does not operate normally, has been dropped, or used or setup in a manner not in accordance with this manual.



The components and parts of the packaging materials or the plastic sacks might pose danger of suffocation for small children if swallowed or used as playing tools. Keep the packaging material out of reach of children.

DISREGARDING THESE WARNINGS MAY CAUSE FIRE, ELECTRIC SHOCK OR OTHER SERIOUS INJURY!

NEVER REMOVE THE COVER OF THE BLACK BOX BETWEEN THE LEGS OF THE SPEAKER!

FCC Statement

This equipment has been tested and found to comply with the limits for a Class B digital device, pursuant to Part 15 of the FCC Rules. These limits are designed to provide reasonable protection against harmful interference in a residential installation.

This equipment generates, uses, and can radiate radio frequency energy and, if not installed and used in accordance with the instructions, may cause harmful interference to radio communications. However, there is no guarantee that interference will not occur in a particular installation. If this equipment does cause harmful interference to radio or television reception, which can be determined by turning the equipment off and on, the user is encouraged to try to correct the interference by one or more of the following measures:

- Reorient or relocate the receiving antenna.
- Increase the separation between the equipment and receiver.
- Connect the equipment into an outlet on a circuit different from that to which the receiver is connected.
- Consult the dealer or an experienced radio/TV technician for help.

Any unauthorized changes or modifications to this equipment will VOID the user's authority to operate this device and VOID its warranty.

This device complies with Part 15 of the FCC Rules. Operation is subject to the following two conditions: (1) This device may not cause harmful interference, and (2) this device must accept any interference received, including interference that may cause undesired operation.

Precautions

- Before connecting the AC adapter to the speakers, make sure the voltage designation of the speakers corresponds to the local electrical supply. If you are unsure of your power supply, contact your local power company or electrician. The acceptable power input range is AC 110V–120V~ / 220V–240V~, 50/60Hz.
- The apparatus with CLASS I construction shall be connected to a receptacle (MAINS) socket outlet with a protective earthing connection.
- The speakers still receiving power from the AC power source as long as it is connected to the wall outlet.
- Unplug the power cord if you are not going to use the speakers for an extended period of time. Hold the power plug when unplugging the unit from the wall. Do not pull on the cord.
- The main plug is used as the mechanism for cutting off power (there is no on/off switch) on the speakers), therefore make sure that both speakers are easy to unplug.
- High temperature will lead to abnormal operation of this speakers. Do not expose these speakers to direct sunlight or do not place it near other objects that generate heat.

- When moving the speakers from a cold location to a warm one, or vice versa, moisture may condense on the electronic parts inside the speakers. In such a case, wait 1-2 hours before connecting the speakers to the electric outlet to facilitate moisture evaporation. Should this occur, the speakers may not operate properly and could fail. This will VOID the warranty.
- The speakers run on DC12V. Please ONLY use the power supply included with the speaker. It delivers a regulated DC12V supply to the electronics built into the black box. There are high voltage components in the black box; DO NOT OPEN the box. Opening the box will VOID your warranty.
- Should a speaker become wet for any reason, immediately disconnect the speaker from the wall outlet. If water spills onto the panel or black box, wait until the speaker becomes completely dry again via evaporation! Do not try to dry the speaker with hair dryer or with other external heat source! If some other type of liquid gets on a panel, do not plug your speaker back into the wall and immediately call your dealer.
- Install the speakers in a place where the temperature and the humidity is in the range of the recommendation of the manufacturer. The speaker may not be operated in areas where relative humidity exceeds 70%! Vapor or humidity condensed in the speaker in a wet environment may cause fire, short circuit; and in the worst case cause a fire or severe damage in the speaker.
- The speakers can generate extremely high sound pressure levels that might damage your hearing. To avoid eventual damage to your ears, please avoid to listen to the at extreme volume.
- The recommended maximum power handling capacity of the speakers is approximately 100 watts per channel. The apparatus can withhold even much larger load but operating the speaker for a long time on high load might be harmful to the speaker.
- To avoid the degradation of the sound quality, do not install the speakers near high power electric equipment like washing machine, electric motors, or large transformers.
- No naked flame sources, such as lighted candles, should be placed on or near the speakers because they may cause fire, could damage to the speakers or could cause injuries.
- Before moving a speaker, unplug the power cord from the electric outlet!
- Carefully follow all the safety instructions in this manual pertaining to connecting the speakers to an amplifier or other electrical equipment.
- Never touch the film panel. Doing so may harm your speakers and will VOID the warranty.
- As discussion in section VI, NEVER remove the lower most foam insert from the speakers. Doing so may harm your speakers and will VOID the warranty.
- Please consult your dealer or the authorized service station in case of any malfunction of the speaker.

II. TECHNICAL DATA

WR1.24 SE	
Purely electrostatic speaker	-
Additional ribbon high frequency planar transducer	•
Self-resetting protection against eventual overload with indicator LED	•
Bi-wiring/Bi-amping connection (two pair of binding post)	-
Wing (controlled deep frequency response)	-
Integrated LED light on front side (can be turned off)	-
Fine tuning/room acoustic adaptation has to be done with foam inlets	•
Transparent speaker without cover	•
Front- and backside fabric cover	-
Foil Thickness	6 μ m
Foil size	0,6 m ²
Frequency response	35-22.000 Hz
Sensitivity	92 dB
Maximum sound pressure	105 dB
Nominal impedance	6 Ω
Lowest impedance	4 Ω
DC resistance	3,2 Ω
THD	<0.2%
Recommended Input Power	30-200 W
Max. input power	250 W
Net Weight/pc	56 kg
Net Dimensions	1793x540x436mm

- The external power supply adaptor**

The required DC 12V voltage for the operation of the Popori Acoustics electrostatic speakers is provided by a short circuit protected external power adaptor, featuring all the applicable certifications (CE, FTZ, UL, FCC, etc.). The low power, high voltage current needed for the electrostatic charge of the foil is produced by the electronics and transformers mounted inside the sealed and properly protected black box located between the legs of the speakers. Possible electric shock is eliminated as long as the black box remains closed. Using the standard external power adaptor and the appropriate power cord, the speaker may be installed and operated at almost any place in the world.

III. UNIQUE CHARACTERISTICS OF POPORI ACOSUTICS ELECTRO-STATIC SPEAKERS

- **Full range electrostatic speakers without dynamic speakers**

All of the Popori Acosutics electrostatic loudspeakers reproduce music over an audio band never before possible with electrostatic speakers. Our largest model (XR1.23) is capable of reproducing music over the almost entire human range of hearing, offered at extraordinary sound pressure levels with vanishingly low levels of distortion. Our loudspeakers produce absolutely natural, life-like, full bodied sound reproduction WITHOUT using any dynamic drivers or subwoofers. The smallest of Popori Acoustics electrostatic speakers (W360) has a frequency range of 40 to 20,000 Hz, while the top model (XR1.23) provides linear frequency response from 25 Hz to 22,000 kHz. The full frequency range of our speakers is reproduced by a single electrostatic panel. Because of this, we do not need to deal with one of the most difficult tasks in hybrid designs; namely synchronizing the super fast electrostatic panel with the slower dynamic woofer or subwoofer. Utilizing a totally different technology than other electrostatic speakers, the Popori Acoustics speakers provide completely homogeneous sound, resembling a live musical performance as it was performed in the actual recorded venue.

- **Impressive sound pressure/high sensitivity**

Thanks to our proprietary production technologies and the technical solutions, the Popori Electronics electrostatic speakers can generate up to 110 dB of sound pressure, enough to fill a reasonably large room with impressive sound. The sensitivity of our speakers is model dependent and ranges from 85 to 96 dB. This means that even an amplifier with moderate power output can easily drive our speakers., There is no need to purchase costly, massive high power amplifiers to enjoy the music at a reasonable volume. Our speakers, driven by a moderately power integrated amplifier (i.e. a 35 WPC tube integrated amp), is often sufficient to produce a very dynamic sound in an about 40 square metres (over 400 sq ft) room with almost unmeasurable distortion.

- **Impedance stability**

Generally, other brands of electrostatic speakers exhibit a dramatically rhapsodic impedance curve dependent of the actual frequency. In the case of some well-known models, the impedance might fall down to as low as 0.5 ohms in the bass and rise to over 30 ohms in the high frequencies. This places a tremendous burdon on even the most stoughtly built, high-power solid state amplifiers, and the kiss of death and a puff to smoke for anything less.

The electrostatic speakers of Popori Acoustics, thanks to an ingeniously engineering solution, produce well-controlled impedance values over all frequencies. Our speakers' unique design and construction guarantees that their impedance never falls below 3.5 ohms

- **100% of the panel radiates**

Presently among all available electrostatic panels manufacturers, the Popori Acoustics models are the only panels that use 100% of the foil for sound radiation. There is not a single square centimeter of unused surface area. This is the result of the proprietary string stretching technology designed and developed by Popori's engineers. Using this unique approach, the foil may be stretched both horizontally and vertically with the appropriate force to achieve our demanding design parameters. Even the corners are completely stretched, making them usable for sound generation. This assists our speakers reach their exceptionally high sound pressure levels with such low distortion.

- **High reliability, longevity**

For decades, Mr. Popori, our chief designer, has repaired and refurbished flat panel speakers for a number the major electrostatic speaker manufacturers. Using similar technology that is incorporated into current Popori speakers, Mr. Popori has refurbished flat panel speakers manufactured in the 80's and 90's that still work flawlessly to this day.

Popori speakers use advanced manufacturing technologies, the highest quality components, and precision production methods to secure the longevity and long-lasting reliable operation of our products. Popori speakers will serve their owners for decades with trouble-free music production if used and operated according to the instructions in this manual. With the return of the completed warranty card, Popori provides a 5 year full warranty for its products hand-crafted in Hungary.

IV. MAJOR COMPONENTS OF THE WR1.23, CONTENTS OF THE PACKAGING

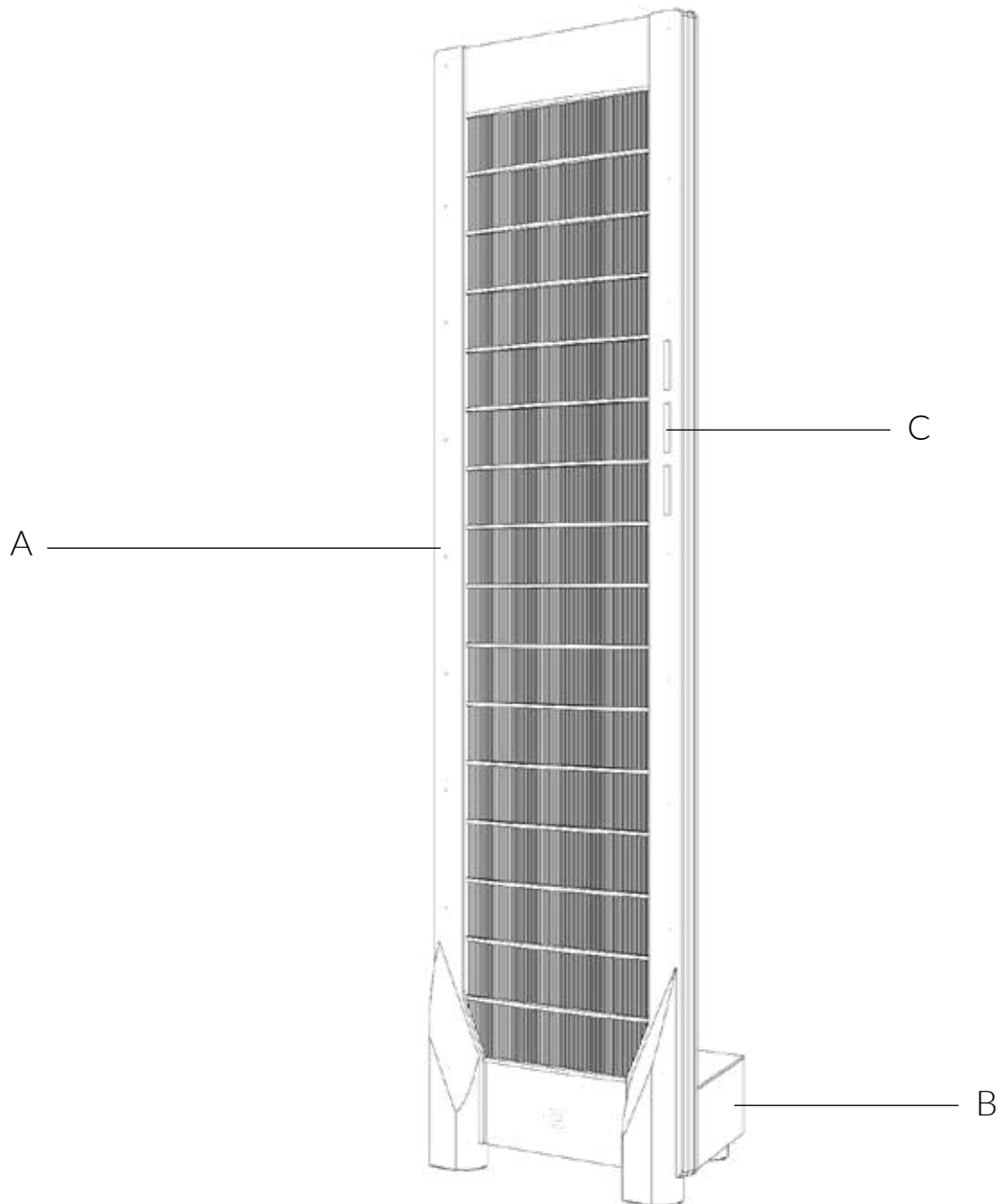

(A) - The electrostatic radiating panel

(B) - The black box containing the electronics

(C) - Tweeter section (ribbon high frequency planar transducer)

The following accessories are packed to each speaker:

AC110-230/DC12V power adaptors	2 pc
Fine tuning sponge inlet	6 pcs
Instruction manual	1 pc
Warranty form	1 pc

V. BACK PANEL CONNECTIONS

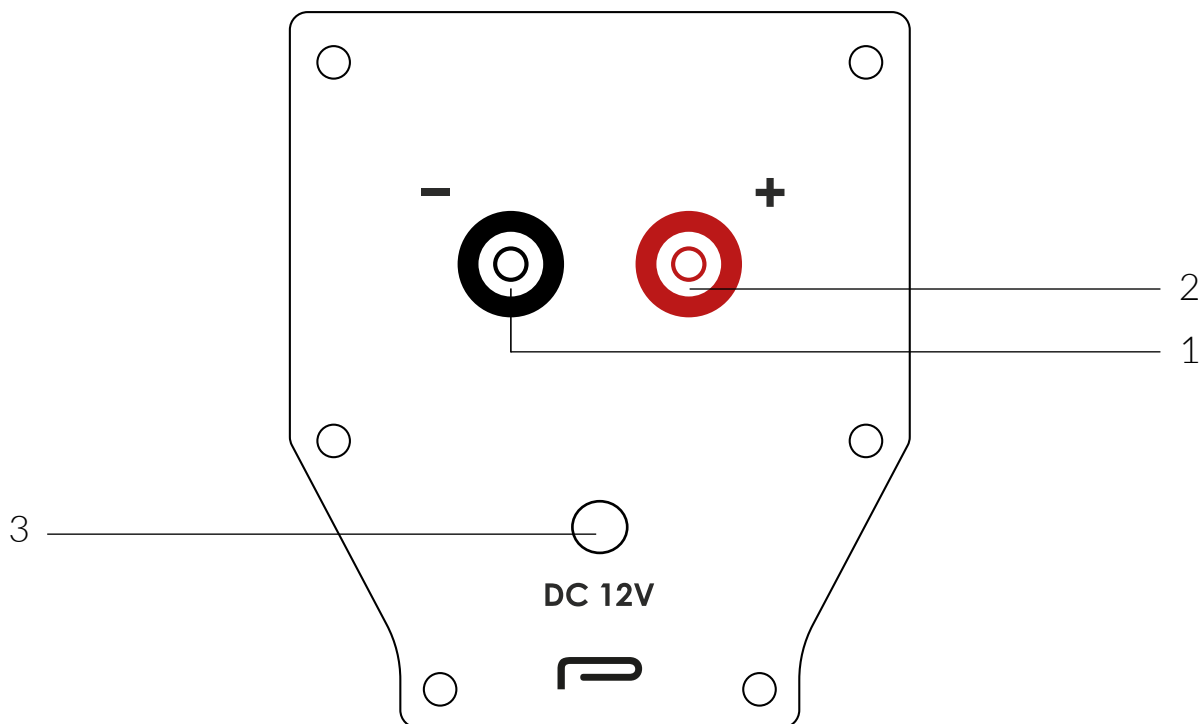

(1-2) - Speaker-level connections.

The binding posts, located on the back side of the black box, receive the audio signal from the amplifier. Properly sized, good quality speaker cable should be used for the connection between the speaker and the amplifier. The gauge of the speaker is not critical, but the cables should be made from high quality materials and have a solid construction.

The amplifier connection methods are described later in the section VI/1.

(3) - DC 12V power connection

The speaker requires DC12V voltage to charge the foil. Directly below the lower binding posts on the back of the black box is the input jack for the DC power supply. First, plug the barrel of the output connector cable of the supplied power adaptor into the jack labeled DC 12V. Next, connect the power cord of the 12V power supply into the electric socket. You will find more details in section VI/2.

EN **VI. PLACEMENT OF THE SPEAKERS**

The electrostatic speakers radiate the sound from both their front and back surfaces with equal power and efficiency. The dispersion radius is much wider than that of dynamic speakers. This enables Popori speakers to provide a larger, more realistic sound stage with reduced distortion.

Because of the free radiating pattern of our speakers, their placement can require a little more effort than a box speaker. The speakers are impacted by the amount of damping, location, and the physical parameters of the given listening area. A lot of heavy upholstered furniture, thick and heavy curtains, textile tapestry, or large furniture pieces significantly influence the sound. In such an environment, the level and intensity of the high frequencies will be significantly reduced and result in a somewhat duller, less colorful sound. You can compensate for that by reducing the level and intensity of the deep frequencies by adding additional tuning acoustic foam inlets. As you fill more inlets with the foam, you will lessen the intensity of the deep frequencies, and thus balance the entire frequency range. On the other hand, if you desire a brighter more detailed sound, you can place the speakers a bit further away from the walls, corners, or large furniture pieces.

In empty rooms or areas with less or lighter furniture pieces, the speakers will produce more bass, echoes, less natural sound. Properly installing acoustically damping foam, bass traps, and acoustical treatment may help to improve the situation. A more natural, life-like sound can also be experienced by pushing the speakers away from the walls and corners.

In optimal case, the speakers should be positioned at least 40 to 60 centimeters (16" to 24") from the walls and about 35-50 cm (14" to 20") from the corners. Try start your positioning in this range.

We recommend that you toe in the speakers so that a virtual line drawn from the central axes of the speakers cross each other slightly behind the listening position.

The ideal distance between the inner edges of the speakers should be 2 – 2.5 meter (6' to 8'). Please note that the edge of the speakers with the built-in ribbon tweeter should be the outer edge of the speaker! While the electrostatic speakers, due to their construction, generate a wide and deep sound stage in which the listener may enjoy a natural, realistic three dimensional sound, the best listening area is the space at a distance of about 2 m (6') from the front plane of the speakers, in the area between the inner edges [facing towards the equipment rack] of the speakers..

We recommend you position the speakers absolute vertically. However, a more direct and better defined sound may be generated in some cases if you tilt the speaker slightly backwards by putting max. 2-3 cm (1") underlay (shim) from suitable materials (stone, hard wood, metal. etc.) beneath the front legs of the speaker.

The mass of the sound generating foil is just a few grams and moves in an open space. Accordingly, the panel does not generate a significant amount of resonance in the frame. Contrary to the membrane of the dynamic speakers, our frame is less sensitive to the resonances coming from the environment. Therefore the relatively heavy steel frame covered by Corian and the heavy steel legs provide the appropriate resonance damping effect. There is no need for spikes or other resonance damping devices. Should the speaker be installed in an extremely resonant environment, or in case of light wooden floor, you may use a heavy damping plate between the floor and the legs of the speakers.

VII. INSTALLING AND SETTING UP OF THE SPEAKER

VII/1 Connecting the speakers to the amplifier(s).

WARNING! Before connecting the speakers to the amplifier, please disconnect the power supply both at the amplifier and at the speakers to avoid any potential damage to the amplifier and to the speaker.

Each speaker pair has two pairs of binding posts on the rear of its black box.

- The signals from the amplifier that are sent to the upper binding posts, marked as HIGH +/-, are used to drive the ribbon tweeter built into the frame of the speaker.
- The signals from the amplifier that are sent to the lower binding posts, marked as LOW-MID +/-, are used to drive the midrange and low frequency segments of the large electrostatic foil.

Amplifier / cable connection options

Attention!

The improper connection of the speaker cable may cause damage to the amplifier and/or to the speaker! Pay attention to the right polarity and to the appropriate color coding (red to red, black to black)! In case you are using stripped wires or spades, connect them tightly to the binding posts to avoid the bare wires or spades from touching each other or the metal case of the amplifier. If the ends of the cables touch each other or touch metal, it can cause a short circuit that can destroy the amplifier.

Because there are two sets of binding posts, there are several methods for connecting the amplifier(s). The difference between the connecting modes will be presented here from point of view of the signal connection only. The pro and cons of the various methods will not be discussed here.

Normal connection

(single amp - single cable connection):

With this connection method, you will use a single run of speaker cable that has one positive (red) and one negative (black) wire (lead) on each end of the cable for both the left and right channels. You will attach one end of the speaker cable to the appropriate positive and negative terminals of the amplifier and the other end of the cable to the pair of binding posts on the speaker's black box. Please double check that the polarity is correct at both the amplifier and the speaker.

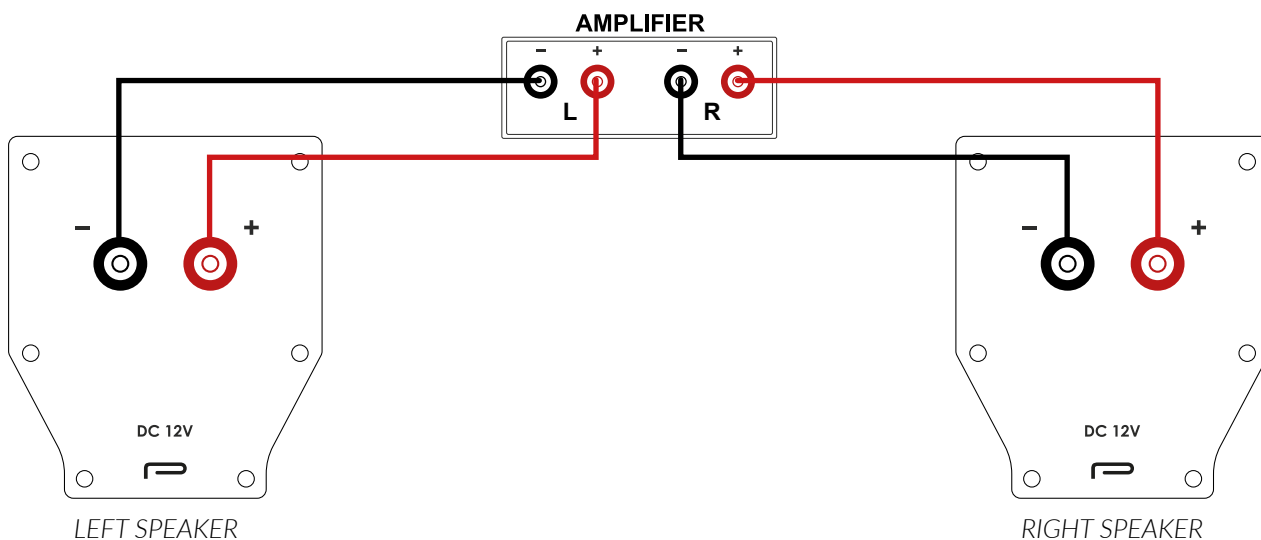

VII/2. Powering the speaker panels

The WR1.23 electrostatic speaker requires 12V direct current (DC) voltage to energize their panels. Two 12V power, short circuit protected, supplies are included with the speakers, one per channel. We recommend using the power supplies included with the speakers, but if for any reason you change it, please always use a short circuit protected one. Any direct or consequential damage caused to the speaker or in the environment caused by the use of a non short circuit protected power supply relieves the manufacturer from all responsibilities and VOIDS the warranty.

Attention!

DO NOT connect the speakers directly to a 110V or 230V outlet! This will severely damage the electronics in the black box and will require costly repair not covered by the warranty. Also, this will VOID the warranty for the speakers!

The speakers do NOT have an On/Off switch. In case you want to cut the power to the speaker, disconnect the power connector either from the speaker or from the electric outlet.

Use only the power supplies included with the speakers! Be careful when connecting and disconnecting the power to the 12V DC socket on the speakers' black boxes. Only do so by handling the round power barrel plugs! Never remove the connection to the speakers by directly pulling the wire. Pulling on the wire may damage the cable and send a surge to the speakers! Contact your dealer and request replacement parts in case the cable or the connector is broken or damaged! Do not use the speaker with a damaged power cable or connector!

Charging of the electrostatic panel

Once plugged in, the speaker requires a time to become fully electro-statically charged. This warm up phase, like other components of the audio system, takes time to reach the best possible operation status and sound quality.

The speaker gets a partial charge immediately after receiving power and it will immediately reproduce music. However, the complete charging time is about 60 to 90 minutes to achieve the best auditory performance. The actual charging time depends on the environmental conditions (e.g. temperature, relative humidity).

VII/3. Fine tuning of the speaker

The construction of the WR1.23 electrostatic speaker makes it possible to fine tune it to the given acoustical environment and to meet the acoustic preferences of the listener. The tuning is particularly effective with deep frequencies. The fine tuning is accomplished by placing of the supplied tuning acoustic foam inlays between the rails on the rear of the speaker. (See the drawing on the right side.)

Your speakers each ship with six sections of acoustic foam pre-installed. The larger the area of the panel that is covered in the rear, the more damped and controlled is the electrostatic panel. The amount of foam applied also will reduce the bass frequency extension, so there can be a trade-off.

For finer tuning, you may cut the foam into narrower widths; however, do not reduce the overall height of the form. It must fit snugly between the ribs.

Finding the ideal quantity and locations of the foam for your room's acoustics and your personal tastes will take time and experimentation, but it worth the effort.

Also, you may achieve various sound effects by adjusting the thickness of the acoustic foam and use alternative materials. For example, you can use cotton or other similarly soft materials with a good damping factor. **DO NOT** use any hard materials as they may damage the foil or the wire mesh. Such damage is not covered under the Popori warranty.

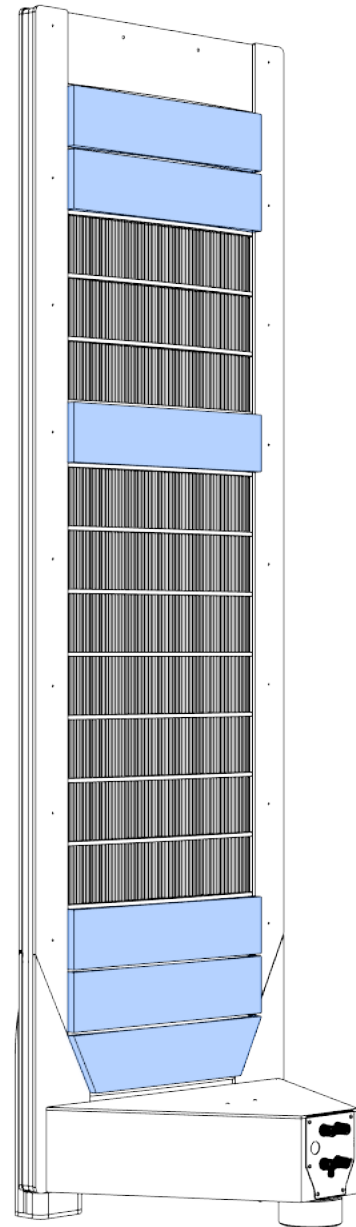

VIII. CLEANING AND MAINTENANCE

ATTENTION!

**IT IS STRICTLY FORBIDDEN to use vacuum cleaner for cleaning of the speaker!
NEVER touch the membrane (the foil) of the speaker with your hands or anything else! Use the fine brush supplied as an accessory with the speakers to clean the wire mesh (stator) of the speaker (not the foil).**

Please be very careful when you clean the strings (wires). DO NOT touch the foil membrane! The dust on the frame or on the wire mesh in front of or behind the foil may be removed by soft, dry or very slightly moistured (water only) lint-free cleaning cloths. The frame, the legs, the black box, and between the legs of the speakers also may be cleaned by soft, dry or slightly moistured (water only) lint-free cleaning cloths.

Never use any cleaning chemicals, polish, thinners, acetone, acidic, or alkaline substances for cleaning any part of the speakers!

NOW SIT BACK AND ENJOY!

POPORI ACOUSTICS LTD.

HUNGARY 6500 BAJA

Szegedi st. 86.

www.poporiacoustics.com

info@poporiacoustics.com

Your Popori Acoustics distributor/dealer:



© All rights reserved